



Concert Choir Virtual Learning

High School Piano

May 12, 2020



High School Concert Choir

Lesson: May 12, 2020

Objective/Learning Target: Students will be able to learn and play new scales- Eb, A, Em and Ab Major.

BELL WORK

- Go to <https://www.musictheory.net/exercises/keysig>
- Review your key signatures
 - Reminder:
 - Order of Flats: BEADGCF
 - Order of Sharps: FCGDAEB
- Review scales: C, G, F, D, and Bb



NEW SCALE- KEY OF Eb MAJOR

- Go to virtualpiano.net
- The key of Eb Major has three flats... Bb, Eb, and Ab
- The scale is:
 - Eb F G Ab Bb C D Eb
 - Find the whole and half steps
 - W W H W W W H
- Play through the scale a couple times

E-flat major scale

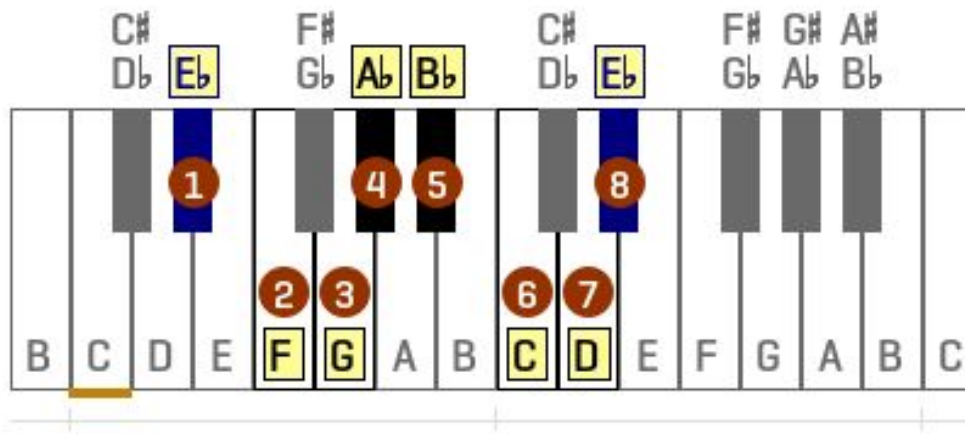

PRACTICE IN E_b MAJOR

Clap the rhythm and identify the note names

Keep a steady beat and play it through a couple of times

2 3 4

NEW SCALE- A MAJOR

- The key of A Major has three sharps... F#, C#, G#
- The scale is:
 - A B C# D E F# G# A
 - Find the whole and half steps
 - W W H W W W H
- Play through the scale a couple times

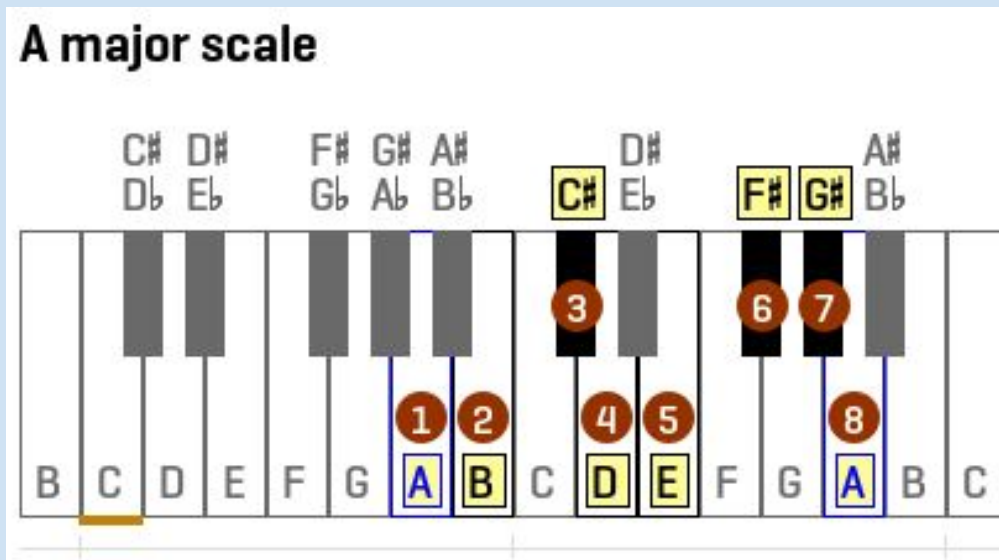

PRACTICE IN A MAJOR

Clap the rhythm and identify the note names

Keep a steady beat and play it through a couple of times

Musical score for 'PRACTICE IN A MAJOR' in 4/4 time, featuring a treble and bass clef with a key signature of one sharp (F#). The melody consists of quarter notes and half notes, with fingerings 2, 3, and 4 indicated above the staff.

The score is written in 4/4 time and consists of two staves. The key signature is one sharp (F#). The melody is written in the treble clef and the bass clef. The melody consists of quarter notes and half notes. The fingerings 2, 3, and 4 are indicated above the staff.

The melody in the treble clef is: F#4 (quarter), G4 (quarter), A4 (quarter), B4 (quarter), C5 (half), B4 (quarter), A4 (quarter), G4 (quarter), F#4 (quarter), E4 (half), D4 (quarter), C4 (quarter).

The melody in the bass clef is: F#2 (quarter), G2 (quarter), A2 (quarter), B2 (quarter), C3 (half), B2 (quarter), A2 (quarter), G2 (quarter), F#2 (quarter), E2 (half), D2 (quarter), C2 (quarter).

NEW SCALE: E MAJOR

E major scale

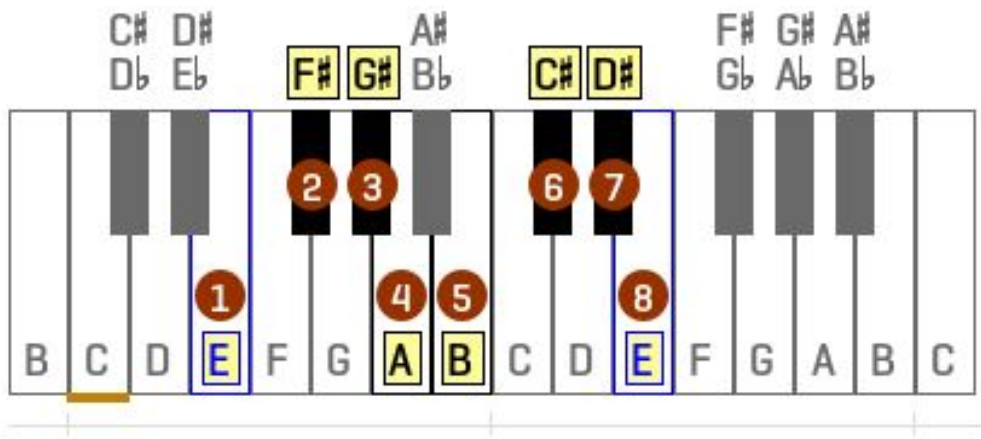

- The key of E Major has four sharps... F#, C#, G#, D#
- The scale is:
 - E F# G# A B C# D# E
 - Find the whole and half steps
 - W W H W W W H
- Play through the scale a couple times

PRACTICE IN E MAJOR

Clap the rhythm and identify the note names

Keep a steady beat and play it through a couple of times

The image shows a musical score for a practice exercise in E Major, 4/4 time. The score consists of two staves: a treble clef staff and a bass clef staff. The key signature is E Major, indicated by three sharps (F#, C#, G#). The time signature is 4/4. The melody in the treble clef starts with a quarter note E4, followed by a quarter note F#4, a quarter note G#4, and a quarter note A4. This is followed by a measure with a quarter note B4, a quarter note C5, and a quarter note D5. The final measure contains a half note E5. The bass line in the bass clef starts with a quarter note E3, followed by a quarter note F#3, a quarter note G#3, and a quarter note A3. This is followed by a measure with a quarter note B3, a quarter note C4, and a quarter note D4. The final measure contains a half note E4. Fingerings are indicated above the notes: '2' above the second measure, '3' above the third measure, and '4' above the fourth measure.

NEW SCALE: A \flat MAJOR

- The key of A \flat Major has four flats... B \flat , E \flat , A \flat , D \flat
- The scale is:
 - A \flat , B \flat , C, D \flat , E \flat , F, G, A \flat
 - Find the whole and half steps
 - W W H W W W H
- Play through the scale a couple times

A-flat major scale

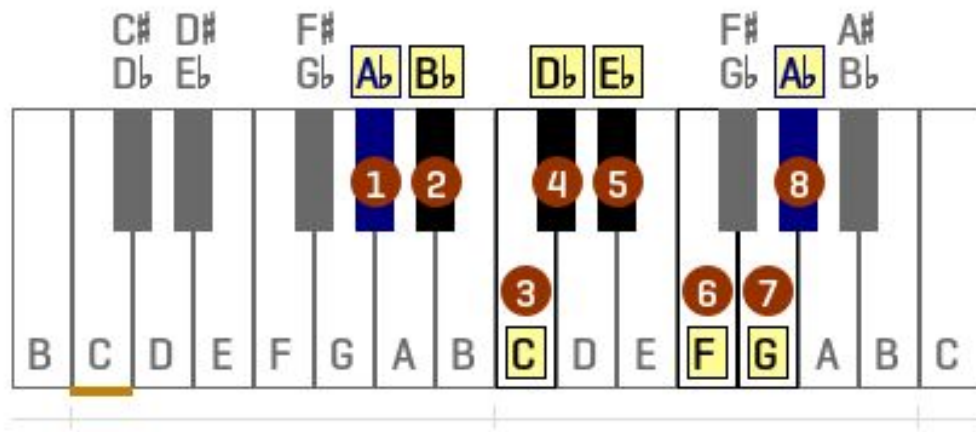

PRACTICE IN A \flat MAJOR

Clap the rhythm and identify the note names

Keep a steady beat and play it through a couple of times

2 3 4

MORE PRACTICE IN NEW KEYS

1. Identify the key signature and time signature
2. Count and clap rhythm
3. Identify starting note name
4. Scan exercise for leaps
5. Play through the exercise

The image shows a musical score for a practice exercise. It consists of two staves: a treble clef staff on top and a bass clef staff on the bottom. The key signature is E-flat major (three flats: B-flat, E-flat, A-flat), and the time signature is 4/4. The exercise is divided into four measures, each starting with a measure rest. The notes are as follows:

Measure	Treble Clef	Bass Clef
1	Whole rest	Whole rest
2	Quarter rest, G4, A4, B4	Quarter rest, F4, G4, A4
3	Quarter rest, G4, F4, E4	Quarter rest, D4, C4, B3
4	Quarter rest, D4, C4, B3	Quarter rest, A3, G3, F3

MORE PRACTICE IN NEW KEYS

1. Identify the key signature and time signature
2. Count and clap rhythm
3. Identify starting note name
4. Scan exercise for leaps
5. Play through the exercise

A musical score for a practice exercise in A major (two sharps) and 4/4 time. The score consists of two staves: a treble clef staff and a bass clef staff. The key signature is A major (F# and C#), and the time signature is 4/4. The exercise is divided into four measures, each starting with a measure rest. The notes are as follows:

Measure	Treble Clef	Bass Clef
1	Quarter rest	Quarter rest
2	Quarter note G4	Quarter note A3
3	Quarter note F#4	Quarter note G3
4	Quarter note E4	Quarter note F3
5	Quarter note D4	Quarter note E3
6	Quarter note C#4	Quarter note D3
7	Quarter note B3	Quarter note C3
8	Quarter note A3	Quarter note B2
9	Half note G3	Half note A2
10	Quarter note F#3	Quarter note G2
11	Quarter note E3	Quarter note F2
12	Quarter note D3	Quarter note E2
13	Quarter note C#3	Quarter note D2
14	Quarter note B2	Quarter note C2
15	Quarter note A2	Quarter note B1

MORE PRACTICE IN NEW KEYS

1. Identify the key signature and time signature
2. Count and clap rhythm
3. Identify starting note name
4. Scan exercise for leaps
5. Play through the exercise

A musical score for a practice exercise in B-flat major (two flats) and 4/4 time. The score consists of two staves: a treble clef staff on top and a bass clef staff on the bottom. The key signature is B-flat major (two flats) and the time signature is 4/4. The exercise is divided into four measures, each starting with a fermata. Above the first measure is the number '2', above the second is '3', and above the third is '4'. The notes in the first measure are G2 (bass), G3 (treble), and G4 (treble). The notes in the second measure are A2 (bass), A3 (treble), and A4 (treble). The notes in the third measure are Bb2 (bass), Bb3 (treble), and Bb4 (treble). The notes in the fourth measure are C3 (bass), C4 (treble), and C5 (treble). The notes are written as quarter notes in the bass clef and quarter notes in the treble clef. The exercise ends with a double bar line.

MORE PRACTICE IN NEW KEYS

1. Identify the key signature and time signature
2. Count and clap rhythm
3. Identify starting note name
4. Scan exercise for leaps
5. Play through the exercise
6. Work on any trouble spots

A musical score for a practice exercise in A major (three sharps) and 4/4 time. The score consists of two staves: a treble clef staff and a bass clef staff. The key signature is A major (F#, C#, G#) and the time signature is 4/4. The melody in the treble clef starts on A4, moves to B4, C5, D5, E5, and then has a double bar line. The bass clef starts on A2, moves to B2, C3, D3, E3, and then has a double bar line. The exercise is divided into four measures, with measure numbers 2, 3, and 4 indicated above the treble staff. The notes in the treble staff are: A4 (quarter), B4 (quarter), C5 (quarter), D5 (quarter), E5 (quarter), A4 (half), and A4 (whole). The notes in the bass staff are: A2 (quarter), B2 (quarter), C3 (quarter), D3 (quarter), E3 (quarter), A2 (half), and A2 (whole).

ONLINE RESOURCES

To help you find your pitch:

- [Virtualpiano.net](https://virtualpiano.net)
- <https://pitchpipe.app/#/>
- Apps for phones
 - Pitch Perfect
 - The Piano

- Sightreadingfactory.com
 - For additional practice!
- Musictheory.net
 - To practice key signatures and note naming

